



 A MESTEK COMPANY



LB2

LIGHT COMMERCIAL ENCLOSURE
FOR TO-THE-FLOOR INSTALLATIONS



A RUGGEDLY BUILT, HEAVY GAUGE AND EASY TO INSTALL BASEBOARD RADIATION SYSTEM FOR THE INSTITUTIONAL MARKET.

- **FRONTS OF HEAVY GAUGE STEEL**-18, 16, or 14 Gauge available.
- **DESIRABLE CHOICE FOR HIGH DENSITY INSTITUTIONAL USE**- student dorms, military housing, nursing homes, apartment houses and the replacement market.
- **LABOR SAVING ROD HANGERS**- are suspended from prepunched slots in the full backplate. No screws or bolts to fasten.
- **NEAT-APPEARING SLIP JOINTED ENCLOSURES**- no sheet metal screws required.
- **OFF-THE-WALL BACKPLATE**- allows enclosures to be installed or removed without damage to finished wall.
- **OPTIONAL DAMPERS**- rugged commercial, fully-modulating damper assembly with durable satin finish knob operator. (Also available with TAMPER-RESISTANT socket head.)
- **ANCHOR-TYPE ACCESSORIES**- all accessories return and attach to wall at bottom of enclosure. This eliminates the need for screws while it adds rigidity to the enclosure.
- **PENCIL-PROOF LOUVERED OPENINGS**- prevents trash accumulation on element.
- **BROAD CHOICE OF ELEMENTS**- Available in both copper and steel. Wide variety of sizes and outputs. All elements completely enclosed within the enclosure.
- **DURABLE FINISH**- all enclosures are chemically phosphatized before application of a baked powder finish. (See Color Selector for standard finishes.)



Full Backplate



Partial Backplate

All Sterling commercial hydronic products are made from recycled materials.

FULL BACKPLATE INSTALLATION

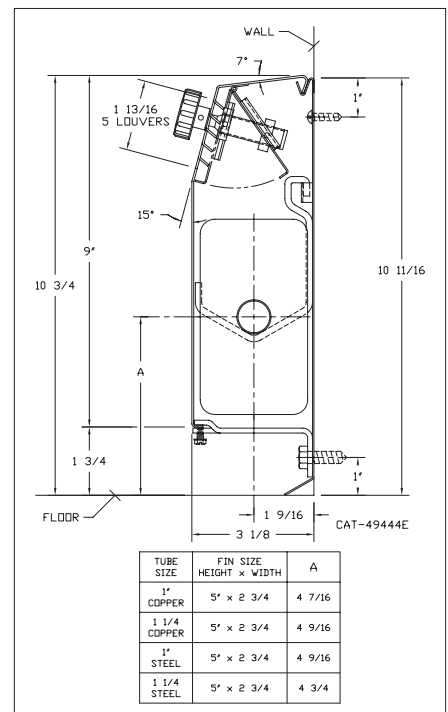
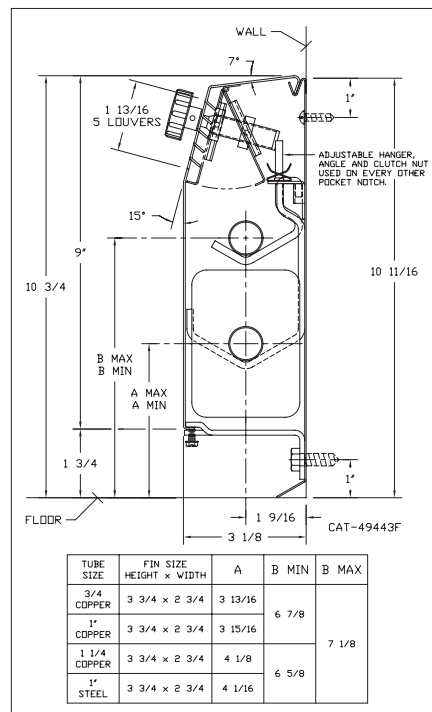
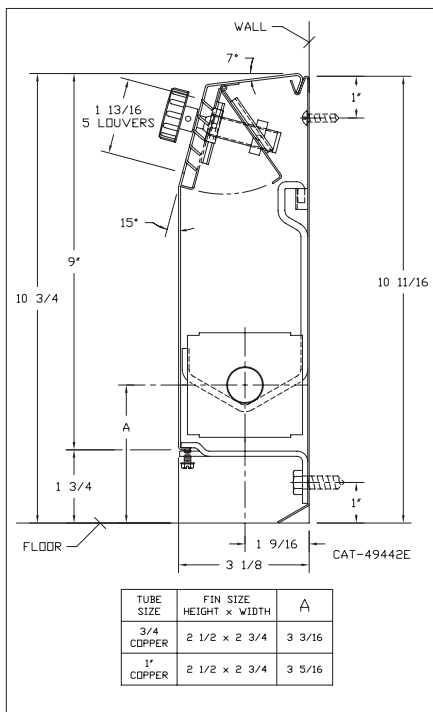

DATA CHARTS

WATER FLOW RATE CORRECTION FACTORS

LB/HR	GPM	FACTOR	PRES. DROP-MILLINCHES/FT. COPPER ELEMENT TUBE SIZE		
			3/4"	1"	1 1/4"
500	1.0	1.000	47	13	6
750	1.5	1.016	96	26	12
1000	2.0	1.028	157	43	20
1250	2.5	1.038	230	63	28
1500	3.0	1.045	320	87	39
1750	3.5	1.051	420	114	50
2000	4.0	1.057	525	145	63
2250	4.5	1.062	650	178	77
2500	5.0	1.067	775	216	93
3000	6.0	1.074	1060	290	124

These are water ratings plus 15% for heating effect. Ratings are based on active length- active finned length is over-all length minus 4" (2" stubs). Ratings are with damper installed. The use of ratings at 4 GPM is limited to installations (usually loop) where the flow rate is 4 GPM or greater. When the flow rate is not known the standard flow rate of 1 GPM must be used.

If the calculated water flow rate through a baseboard unit in a completely designed hot water heating system is greater than the standard flow rate (500 lb./hr.), the rating of that unit may be increased by multiplying the standard water rating at 500 lb./hr. by the factor shown for the calculated flow rate. See chart for correction factors.

NOTE: NPT Threads furnished on steel elements, please use domestic fittings for their proper installation.

STYLE Light Commercial "LB-2"

TUBE SIZE	CATALOG DESIGNATION	FIN SIZE HEIGHT X WIDTH	FINS PER FT.	FIN THICKNESS IN INCHES	WATER RATE IN G.P.M.	HOT WATER (AVG.)									
						215°	200°	190°	180°	170°	160°	150°	140°	130°	120°
3/4"	R02	2-1/2" x 2-3/4"	60	.010	1	1010	890	800	720	630	550	470	390	320	260
					4	1070	940	850	760	670	580	500	420	350	280
1"	R03	2-1/2" x 2-3/4"	55	.011	1	990	870	790	710	620	540	460	390	320	250
					4	1050	920	840	750	660	570	490	410	340	270
3/4"	R04	3-3/4" x 2-3/4"	50	.014	1	1070	950	850	770	680	590	510	430	350	280
					4	1130	1000	900	810	720	620	530	450	370	290
1"	R05	3-3/4" x 2-3/4"	50	.014	1	1080	960	860	780	690	600	520	440	360	290
					4	1140	1010	910	820	730	630	540	450	370	300
1"	R07	5" x 2-3/4"	50	.020	1	1060	930	840	740	650	560	470	390	320	260
					4	1120	980	890	780	680	590	500	420	350	280
1-1/4"	R08	3-3/4" x 2-3/4"	50	.02	1	1070	930	840	740	650	560	470	390	320	260
					4	1130	980	890	780	680	590	500	420	350	280
1-1/4"	R10	5" x 2-3/4"	50	.020	1	1080	940	840	750	660	560	470	390	320	260
					4	1140	990	890	790	690	590	500	420	350	280

COPPER/ALUMINUM ELEMENT RATINGS

ALL RATINGS ARE BASED ON 65° EAT

STYLE Light Commercial "LB-2"

TUBE SIZE	CATALOG DESIGNATION	FIN SIZE HEIGHT X WIDTH	FINS PER FT.	FIN THICKNESS IN INCHES	WATER RATE IN G.P.M.	HOT WATER (AVG.)									
						215°	200°	190°	180°	170°	160°	150°	140°	130°	120°
1"	R12	5" x 2-3/4"	50	.024	1	1000	880	800	720	630	550	470	390	320	260
					4	1060	930	850	760	670	580	500	420	350	280
1-1/4"	R13	5" x 2-3/4"	50	.024	1	1020	900	810	730	640	560	480	400	330	260
					4	1080	960	860	770	680	590	510	430	350	280

STEEL ELEMENT RATINGS

ALL RATINGS ARE BASED ON 65° EAT

PARTIAL BACKPLATE INSTALLATION

Element Cradle with Ball Bearing Installation

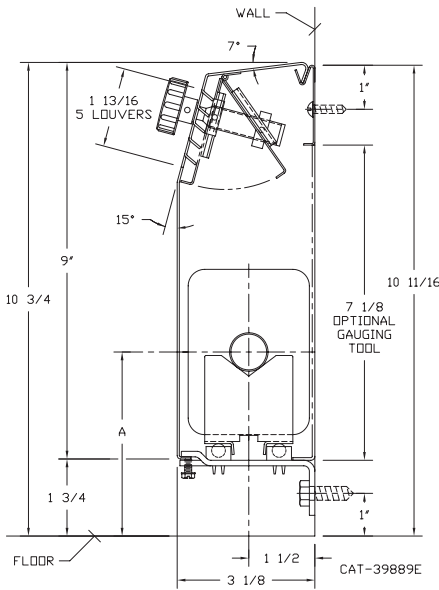

Rod Hanger Installation

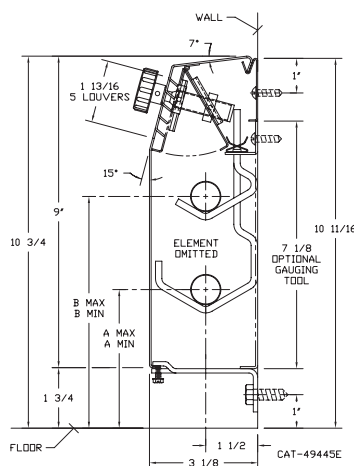
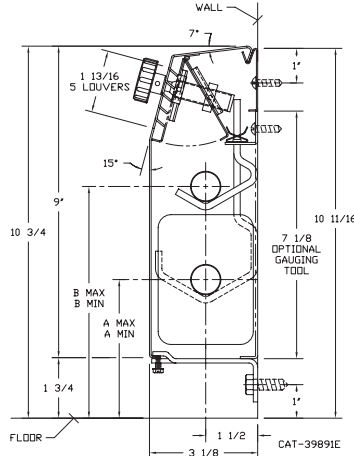

TUBE SIZE	FIN SIZE HEIGHT x WIDTH	A MIN	A MAX	B MIN	B MAX
3/4" COPPER	2 1/2 x 2 1/4	3 1/4	5 1/4	6 1/8	7 1/8
	2 1/2 x 2 3/4	3 7/8	5 3/8	6 5/8	7 1/8
	3 3/4 x 2 3/4	3 7/8	5 3/8	6 5/8	7 1/8
1" COPPER	2 1/2 x 2 3/4	3 1/4	5 1/4	6 1/8	7 1/8
	3 3/4 x 2 3/4	3 7/8	5 3/8	6 5/8	7 1/8
	5" x 2 3/4	4 1/2	5 1/4	N/A	N/A
1 1/4" COPPER	3 3/4 x 2 3/4	3 7/8	5 3/8	6 5/8	7 1/8
1" STEEL	5" x 2 3/4	4 1/2	5 1/4	N/A	N/A
	3 3/4 x 2 3/4	3 7/8	5 3/8	6 5/8	7 1/8
1 1/4" STEEL	5" x 2 3/4	4 1/2	5 1/4	N/A	N/A
	3 3/4 x 2 3/4	3 7/8	5 3/8	6 5/8	7 1/8

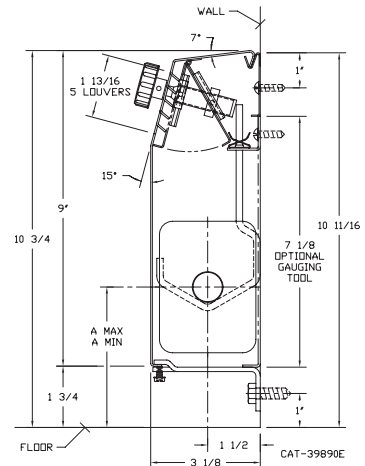

GENERAL LAYOUT

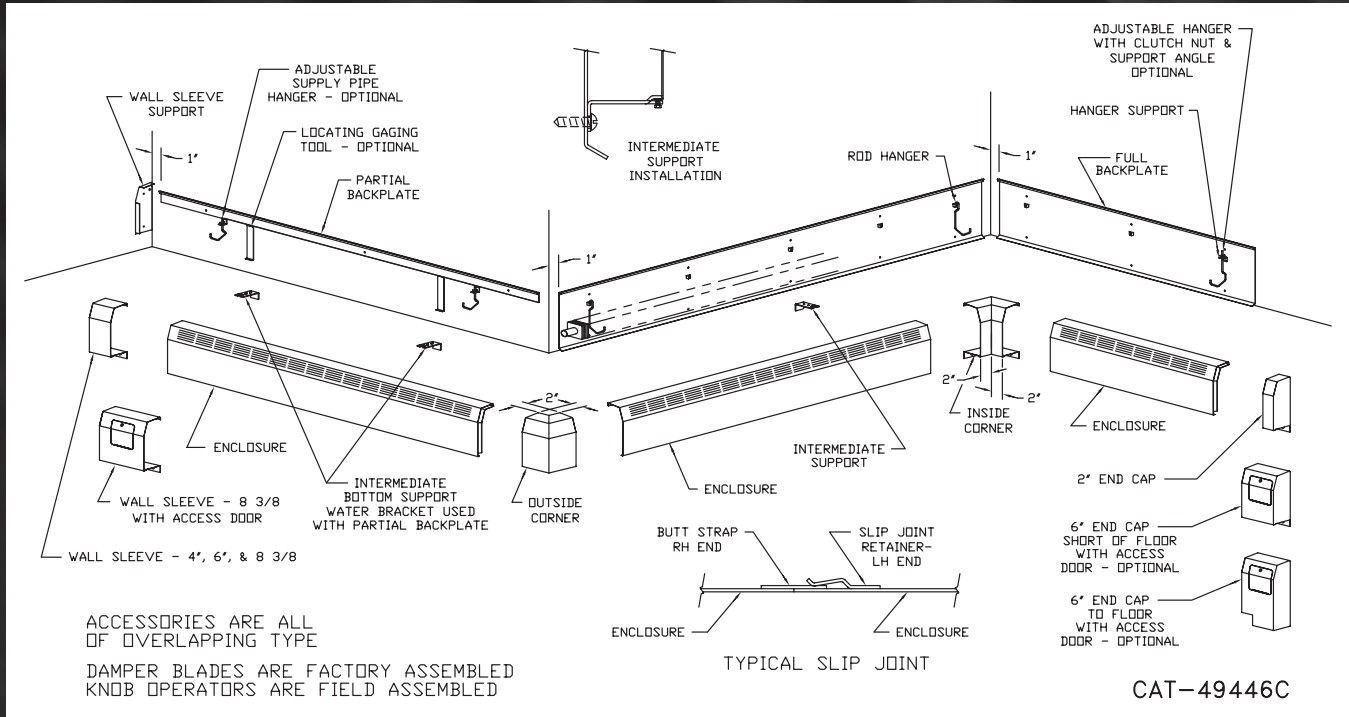

ACCESSORIES



SPECIFICATIONS

Furnish and install where shown on plans, Sterling LB2 Finned Tube Radiation as described in the following specification or approved quality and capacity equal.

Enclosure shall be one piece manufactured of 18 gauge standard (optional 16 or 14 gauge CRS) steel with pencil proof louvered discharge grille. Damper shall be fully-modulating type with satin finish knob or (optional) tamper-resistant socket head operator. Enclosures shall be joined by means of slip joint.

Full back panel (20 gauge) shall be die formed for rigidity and will have prepunched slots for rod hangers. It shall be off-the-wall type allowing for removal of enclosure without damage to finished wall. Partial back plate (20 gauge) shall be pre-painted steel and roll formed. Installations with full backplate will incorporate fixed and/or adjustable element rod hangers.

Installations with partial backplate will incorporate intermediate bottom supports with ball bearings and slide cradles when no pitch is required. Wall-mounted adjustable rod hangers will be used with partial backplate when pitch is required for steam jobs.

All accessories shall be anchor type providing additional support of enclosures.



260 North Elm Street, Westfield MA 01085

Tel: (413) 564-5535

www.sterlingheat.com

